

Smart Control Socket

Data Sheet SCS16

Description

The Cavity Eye Smart Control Socket (SCS) was developed for the Injection Molding Machines (IMM) with Smart Moulding Control system installed. This socket is equipped with a special memory, and responsible for the communication between the Cavity Eye pressure measurement system and the IMM. The analog inputs from the IMM and the analog outputs to the IMM are running through this device; furthermore, it is a necessary counterpart for the Cavity Eye Smart Control Plug (SCP).

Application

The socket is used for cavity pressure measurement in injection moulds as a part of the Cavity Eye system. Indispensable accessory of the Smart Moulding Control (SMC) pressure measurement system.

Fulfills the industry's requirements by having a heavy-duty design with IP64 protection rating. Easy to install on every IMM, it is pronouncedly made for industrial applications.

How does it work

The socket is responsible for the wired connection of the input signals of the IMM and the output signals of the Cavity Eye system. The socket is capable of handling 16 in- and output 24 V analog signals at the same time. A specific amount is allocated for the basic signals of the Cavity Eye system by default, the other in- and outputs are freely programmable. Additionally, the Cavity Eye Smart Control Plug is connected to the SCS.

The socket is capable of storing the identifications and the data of the IMM, the pins' allocations, and the data of the input signals in the integrated memory.

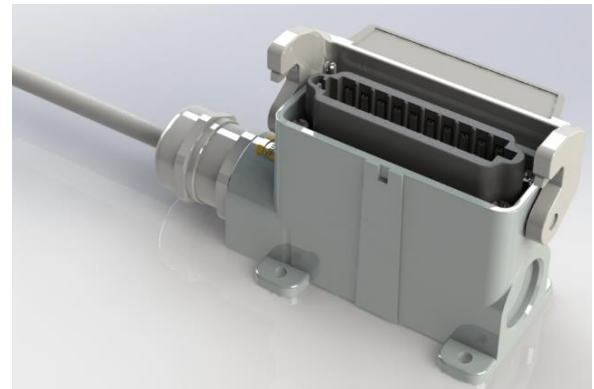

Technical data

SCS16		
Weight	g	290
Main Dimensions	mm	130x75x57
Operating temperature range	°C	0 - +80
Power Supply	V	24
Protection rating	IEC 60529:1989	IP64
In- and outputs	pcs	16
Number of pins	pcs	20

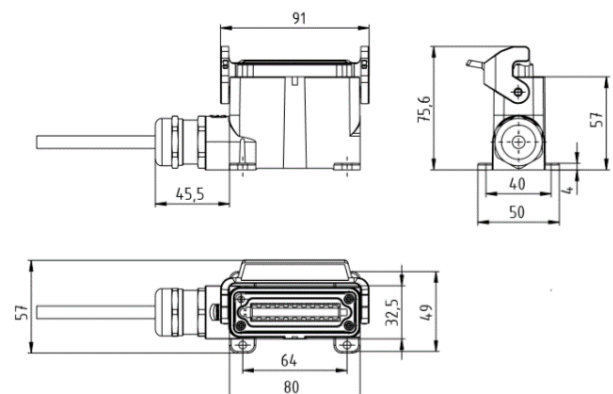

1. Figure: Main dimensions of the device

Placement

In case of using the measurement system with an assigned, Cavity Eye IMM – so the devices are not disconnected frequently – then the socket should be placed in the low voltage cabinet of the IMM. Making the system fixed on the machine can either be done by self-tapping screws, or by 4 pieces of M4 bolts and nuts. Quicker mounting process is achievable by using 4 pieces of magnets on the side of the cabinet.

In case of using the measurement system with multiple injection moulding machines, the socket recommended to be placed outside of the IMM, for example at the outside of the low voltage cabinet or other easily accessible locations. The self-tapping screw or the 4 pcs of M4 bolts and nuts solution is recommended for such locations; furthermore, an extra hole (or an existing one) is necessary for the socket's wirings to lead in to the IMM.

Electrical wirings

The connection of the SCS16 socket's wires to the IMM should be performed according to the labeling on the yellow shrink tubes.

The in- and outputs – as labelled on the wires – are connected to the insert accordingly to the table below.

The socket is equipped with an integrated memory module. The memory module is connected to the first two pins of the insert. The data stored in the memory will not be lost in case of disconnecting the SCS from the power.

The 3rd and 4th pins are allocated to the grounding and the constant 24 V voltage of the IMM. The other wirings to the 24 V analog signals of the IMM should be performed by the labels on the wires.

Pin allocation

Pin	Name	Function
1	Memory GND	
2	Memory Data	
3	IMM GND	Grounding
4	IMM 24V	Constant 24V from IMM
5	IMM Trigger	Trigger from IMM
6	IMM Autocycle	IMM automatic cycle active
7	IMM OKNOK	Bad part signal from IMM
8	In 4 (Empty)	
9	CE OK/NOK	Good part signal
10	CE Switch	Switchover signal
11	CE Cycle Stop	Stop IMM at the end of cycle
12	CE Prompt Stop	Stop IMM immediately
13	CE live	CE is on feedback
14	Out 6 (Empty)	
15	Out 7 (Empty)	
16	Out 8 (Empty)	
17	Out 9 (Empty)	
18	Out 10 (Empty)	
19	Out 11 (Empty)	
20	Out 12 (Empty)	

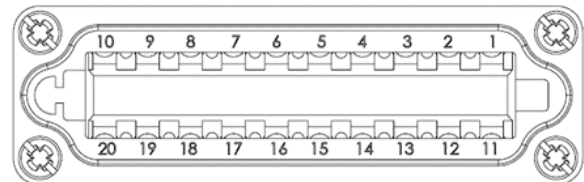

= Input signals to the IMM